

CAST IRON PUMPS AND MOTORS **W2 SERIES**

POMPE E MOTORI IN GHISA SERIE W2

MADE IN ITALY

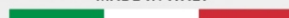

REV MARZO 15



Caratteristiche principali

- Possibilità di funzionare ad alte pressioni: fino a 300 bar di pressione massima in funzionamento continuo.
- Compensazione assiale per il recupero dei giochi
- Alto rendimento volumetrico: 97-99% medio.
- Ampia disponibilità di cilindrata: 4-6-8-11-15 - 20-25-40 cm³/giro.
- Corpo in ghisa
- Progetto accurato del profilo del dente per avere una bassa rumorosità.
- Vasta gamma di flange, alberi e connessioni compatibili con i principali standard del mercato.
- Disponibilità di guarnizioni per alte temperature
- Pompe e motori unidirezionali
- Pompe e motori bidirezionali
- Possibilità di montaggio di pompe multiple sia nelle serie in alluminio che con altre serie in ghisa
- Facilità di trasformazione: da pompa singola in pompa multipla e di cambio rotazione.

Main Features

- *High pressure option: up to 300 bar max. continuous pressure (4350 psi)*
- *Axial compensation achieved using pressure balanced bushing blocks.*
- *High volumetric efficiency: average 95%*
- *Wide range of capacities : 4-6-8-11-15-20-25-40 cm³/rev.*
- *Cast iron body*
- *Gear tooth profile accurately projected providing low noise operation.*
- *A wide variety of shafts, flanges and ports are available to meet specific application requirements.*
- *High-temperature seals available.*
- *Single rotational pumps and motors.*
- *Bi-rotational pumps and motors.*
- *Multiple pumps availability: tandem pumps are possible both in aluminium series and with other cast iron series*
- *Easy-to-make tandem pumps and easy change of rotation.*

CONDIZIONI PER L'UTILIZZO DELLE POMPE "W2"

CONDITIONS OF USE FOR PUMPS "W2"

Nell'utilizzo della pompa evitare carichi radiali e assiali sull'albero.

Il giunto di trascinamento deve compensare eventuali errori di allineamento, deve essere di tipo elastico oppure di tipo Oldham.

Per un corretto funzionamento e una lunga durata della pompa, osservare i valori riportati nella tabella seguente.

Avoid radial and axial loads on the pump shaft during the use.

The pump must be in line with the P.T.O. to compensate misalignment errors, use flexible or "Oldham" coupling.

We recommend to read the specifications in this catalogue very carefully. This will help you in getting the best, in terms of working conditions and life.

CONDIZIONI PER L'UTILIZZO DELLE POM PEW 2
USE CONDITIONS FOR THE PUM PSW 2

Fluidi idraulici Hydraulic fluids	Oli idraulici a base minerale (DIN 51524) Per utilizzo di fluidi non infiammabili come acqua e glicole , emulsione di olio in acqua, o esteri fosforici, contattare il nostro ufficio tecnico o commerciale <i>Mineral oil (DIN 51524)</i> <i>For use with fire resistant fluids like water glycol, water- oil emulsion and phosphate-esters, contact our technical or commercial office.</i>		
Pressione in aspirazione Inlet pressure	0.7 - 3 bar (Assoluti / Absolute) 10 - 44 psi (Assoluti / Absolute)		
Velocità olio nella linea di aspirazione Oil speed on suction line	0.5 ÷ 1.5 m/s		
Velocità olio nella linea di mandata Oil speed on pressure line	6 ÷ 10 m/s		
Temperatura olio Oil temperature	-10°C ÷ 80°C		
Viscosità olio Oil viscosity	20 ÷ 120 mm ² / s (Cst)		
Massima viscosità olio all'avvio Max starting viscosity	700 mm ² / s (Cst)		
Filtraggio olio Oil filtration	Pressione Pressure	< 200 bar	> 200 bar
	Classe di contaminazione NAS1638 <i>Contamination class NAS1638</i>	10	9
	Classe di contaminazione ISO 4406 <i>Contamination class ISO 4406</i>	19/16	18/15
	Rapporto βx ≥ 75 Ratio βx ≥ 75	25µm	10µm

FORM ULE PER DIM ENSIONAM ENTO
DETERMINATION OF NOM INAL SIZE

PER POM PE
FOR PUMP

$$Q = \frac{V \cdot \eta_v \cdot n}{1000}$$

$$M = \frac{p \cdot V}{62.8 \cdot \eta_m}$$

$$P = \frac{p \cdot Q}{600 \cdot \eta_t}$$

PER MOTORI
FORMOTOR

$$Q = \frac{V \cdot n}{1000 \cdot \eta_v}$$

$$M = \frac{p \cdot V \cdot \eta_m}{62.8}$$

$$P = \frac{p \cdot Q \cdot \eta_t}{600}$$

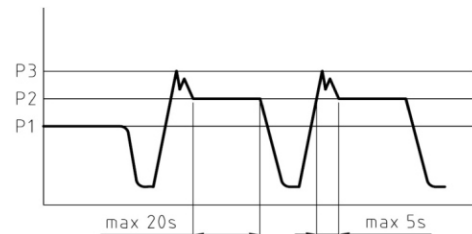

- V [cm³]
 - Q [l/min]
 - p [bar]
 - M [Nm]
 - n [min⁻¹]
 - P [Kw]
- $\eta_v = \text{EFF vol.} \geq 95$
 $\eta_m = \text{EFF mecc.} \sim 0.85$
 $\eta_t = \eta_v \cdot \eta_m. \sim 0.8$

CARATTERISTICHE PRINCIPALI

MAIN CHARACTERISTICS

Tipo - Type		04	06	08	11	15	20	25	40
Clindrata Capacity	$\text{Cm}^3 / \text{giro}$ Cm^3 / rev	4.4	6.28	8.16	11.3	15.5	20.5	26.1	38.8
P1 Pressione max continua Max working pressure	Bar	300	300	300	300	260	230	200	140
P2 Pressione intermittente intermittent pressure	Bar	320	320	320	320	300	250	220	155
P3 Pressione max di picco Max peak pressure	Bar	350	350	350	350	320	270	240	175
Velocità max per pressione P1 Max speed for P1 pressure	Giri / min Rpm	3500	3500	3500	3000	3000	2500	2300	2000
Velocità max a vuoto Max speed without load	Giri / min Rpm	4000	4000	4000	3500	3500	3000	2700	2400
Velocità min. per pressione P1 Min speed for P1 pressure	Giri / min Rpm	400	400	400	350	350	300	300	250

VERIFICARE, ATTRAVERSO LE FORMULE SOTTO RIPORTATE, LA COMPATIBILITÀ TRA LE PRESTAZIONI DI PRESSIONE E PORTATA RICHIESTE E LA CAPACITÀ DEL ALBERO DI TRASCINAMENTO DI SOPPORTARE LA COPPIA RICHIESTA

VERIFY THE COMPATIBILITY AMONG PERFORMANCE OF PRESSURE, FLOW REQUIRED AND TORQUE OF THE SHAFT THROUGH THE BELOW FORMULAS

Per pompe o motori bidirezionali, diminuire la pressione del 15%
With bidirectional pumps or motors, pressure is reduced by 15%

COMPONENTI

PARTS

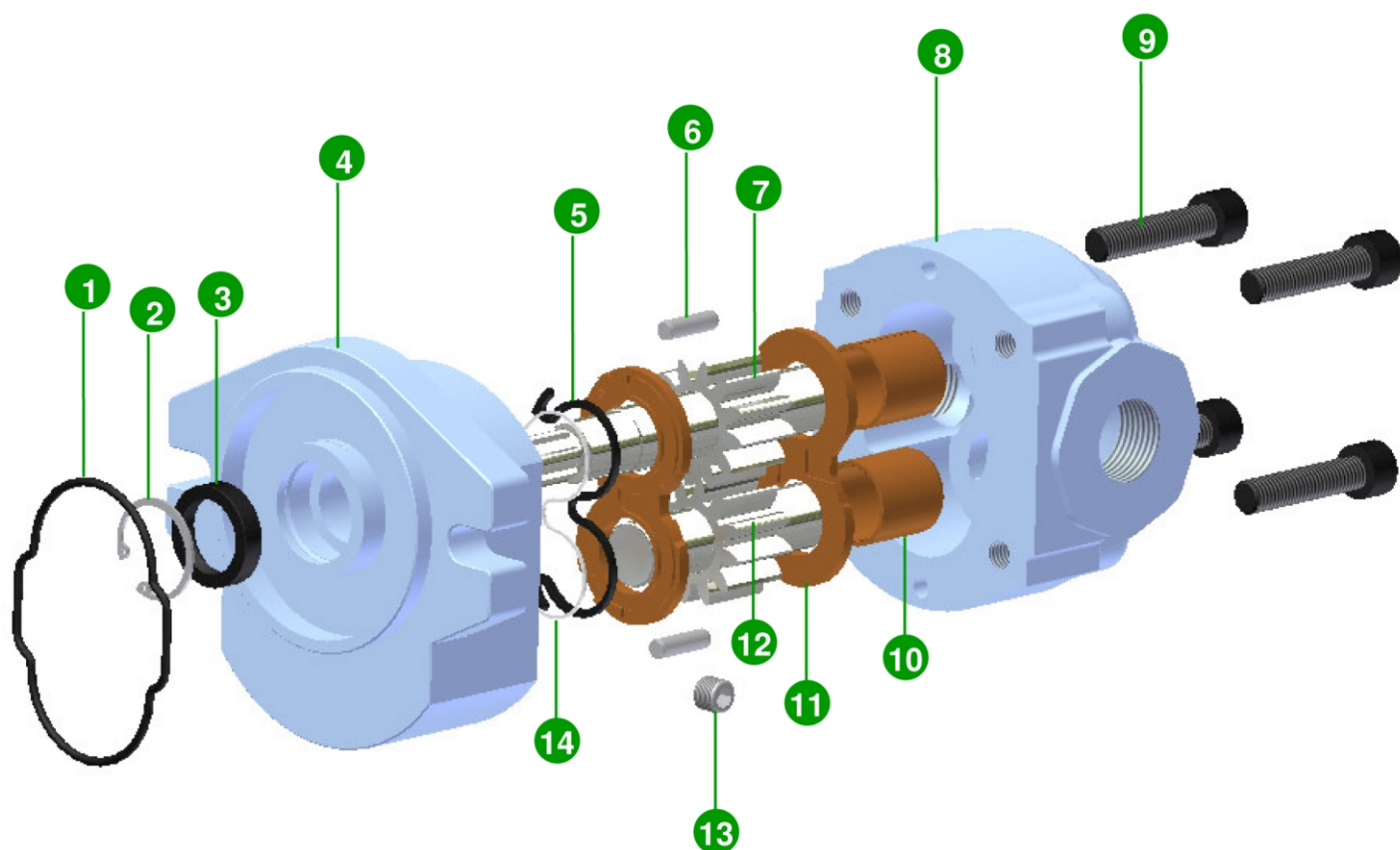

Rif.	Descrizione	Description	Qt.
1	Guarnizione sotto-coperchio	<i>Under cover seal</i>	1
2	Anello elastico	<i>Snap ring</i>	1
3	Anello di tenuta	<i>Rotary shaft seal</i>	1
4	Flangia	<i>Flange</i>	1
5	Guarnizione di compensazione	<i>Compensation seal</i>	2
6	Spina cilindrica	<i>Pin</i>	2
7	Ingranaggio conduttore	<i>Drive gear</i>	1
8	Corpo	<i>Housing</i>	1
9	Vite	<i>Bolt</i>	4
10	Bussole	<i>Bushing</i>	4
11	Rasamento	<i>Thrust plates</i>	2
12	Ingranaggio condotto	<i>Idle gear</i>	1
13	Grano 1/8" G	<i>Grub screw</i>	1
14	Antiestrusore	<i>B-K seals</i>	2

SENSO DI ROTAZIONE

ROTATION

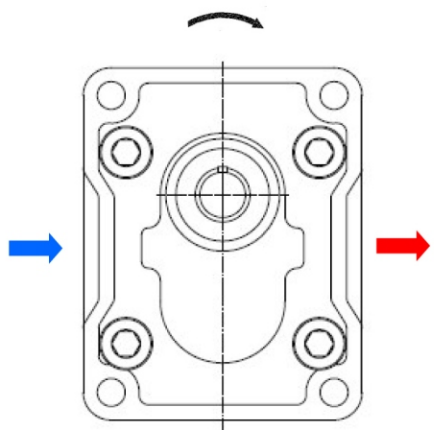

Rotazione destra <i>Clockwise rotation</i>	Codice <i>Code</i>	D
---	-----------------------	----------

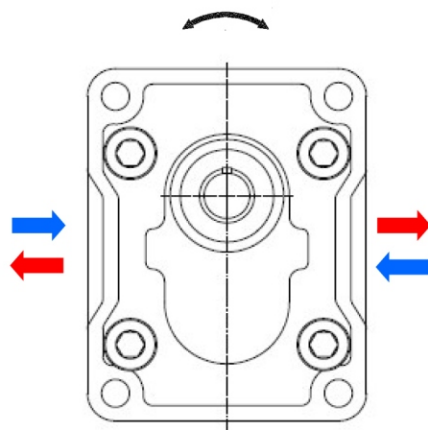

Rotazione bidirezionale drenaggio esterno <i>Bidirectional rotation with external drain</i>	Codice <i>Code</i>	R
Rotazione bidirezionale drenaggio interno <i>Bidirectional rotation with internal drain</i>	Codice <i>Code</i>	Y

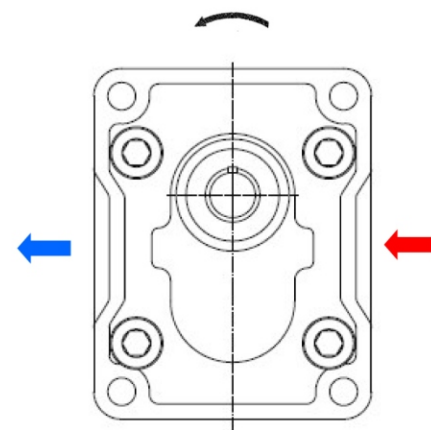

Rotazione sinistra <i>Anti-Clockwise rot.</i>	Codice <i>Code</i>	S
--	-----------------------	----------

GUARNIZIONI PER ALBERI

SHAFT SEAL

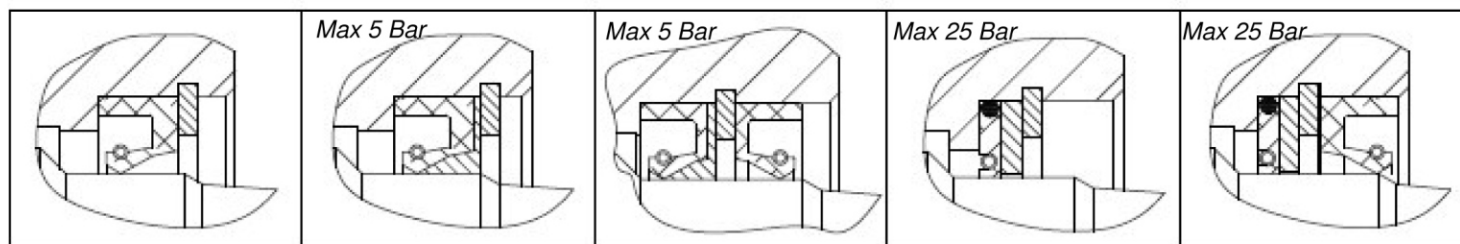

Codice <i>Code</i>	N	NBR
	V	VITON

Codice <i>Code</i>	R	NBR
	RV	VITON

Codice <i>Code</i>	N2	NBR
	V2	VITON

Codice <i>Code</i>	B	NBR
-----------------------	----------	------------

Codice <i>Code</i>	BN	NBR
	BV	VITON

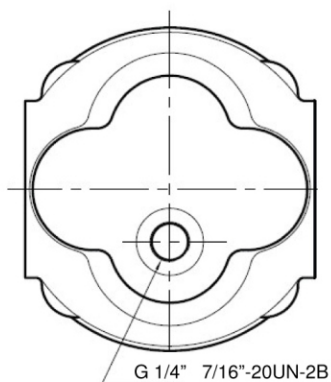

G 3/8" PER BOCHE GAS E METRICHE.
7/16"-20UN-2B PER BOCHE O-RING BOSS e SPLIT

G3/8" FOR GAS AND METRIC PORTS
7/16"-20UN-2B FOR O-RING BOSS AND SPLIT PORTS

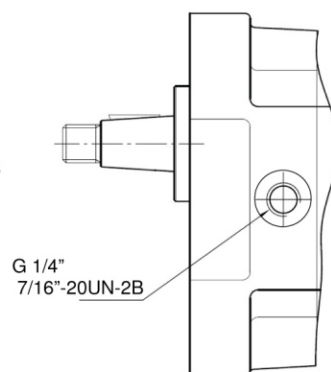

Drenaggio posteriore per pompe o motori reversibili <i>Rear drain for bidirectional pumps or motors</i>	R
---	----------

Drenaggio anteriore per pompe o motori reversibili <i>Front drain for pumps or motors</i>	R1
---	-----------

il codice "R" comprende rotazione bidirezionale, paraolio rinforzato 5 bar e drenaggio posteriore
Code "R" includes bidirectional rotation, reinforced shaft seal 5 bar and rear drain

CAMBIO DEL SENSO DI ROTAZIONE DELLE POMPE W2 CHANGING ROTATION OF THE PUMP W2

Rotazione sinistra
Anticlockwise rotation

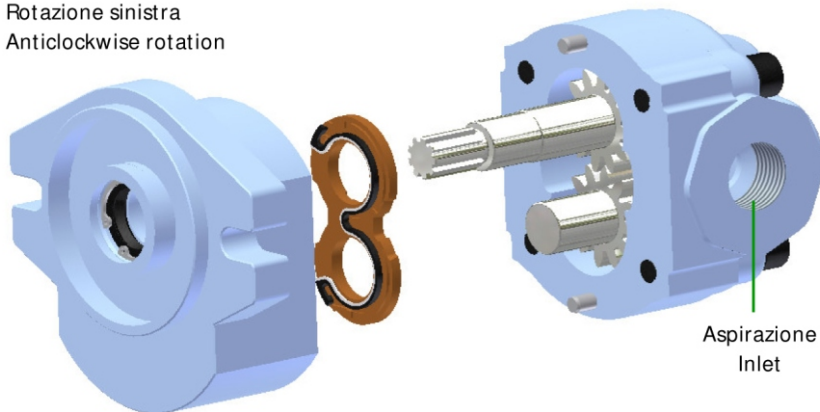

Rotazione destra
Clockwise rotation

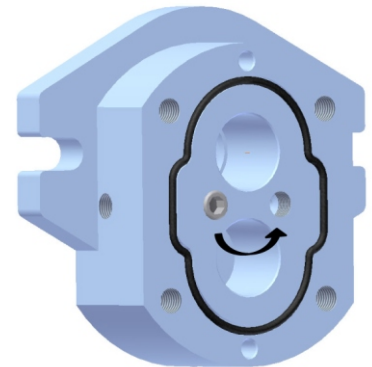
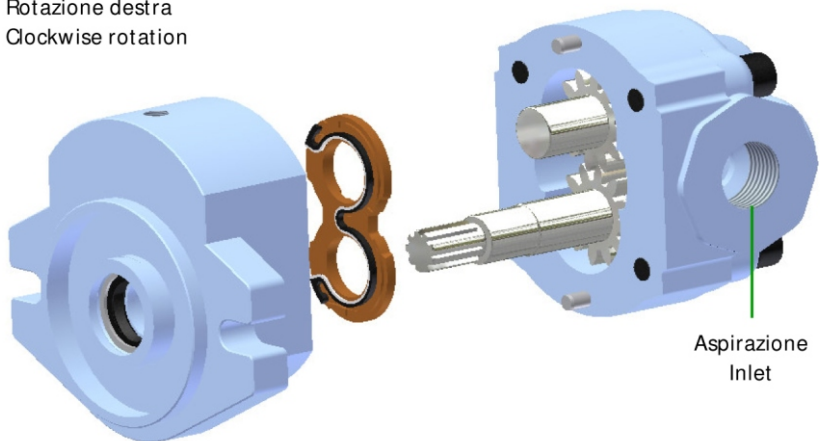

Il senso di rotazione, è indicato con una freccia sul corpo della pompa.
An arrow on the housing of the pump indicates the rotation.

- Svitare le viti di fissaggio.
- Rimuovere la flangia tenendo premuto l'ingranaggio conduttore.
- Rimuovere contemporaneamente l'ingranaggio conduttore e il rasamento superiore mantenevo premuto l'ingranaggio condotto.
- Estrarre l'ingranaggio condotto tenendo fermo il rasamento inferiore, nel caso aiutarsi con una barretta NON metallica.
- Rimontare i due ingranaggi con posizioni invertite (vedi schema sopra).
- Rimontare il rasamento superiore facendo attenzione a NON invertirne la posizione.
- Cambiare di posizione al grano situato sulla faccia interna della flangia.
- Rimontare la flangia utilizzando per le viti una coppia di serraggio di 60-65 Nm.

- *Unscrew the clamping bolts.*
- *Remove the flange holding down the drive gear.*
- *Remove the drive gear and the bushing block holding down the idle gear.*
- *Remove the idle gear keeping down the rear bushing block with a no-metallic bar.*
- *Reverse the position of the two gears (see picture above)*
- *Replace the bushing block without rotate or changing position.*
- *Changing position of the grub screw on the flange (see picture above)*
- *Reverse the flange and retighten the bolts to a torque rating between 44-48 ft/lbs*

FLANGE
FLANGES

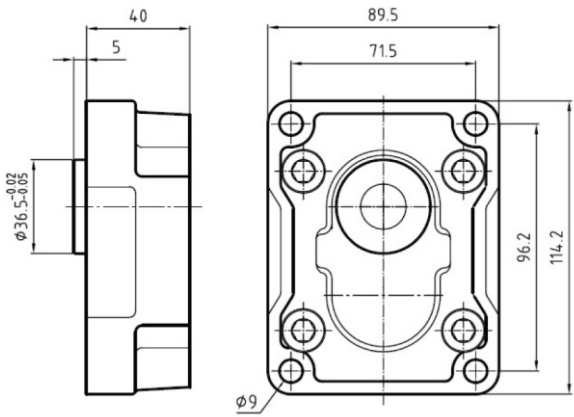

CODICE CODE	E	0
-----------------------	----------	----------

NOTA : Materiale Ghisa
NOTE : Material Cast iron

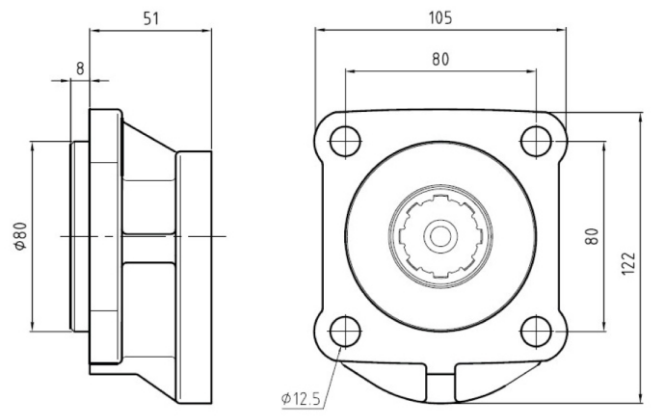

CODICE CODE	I	4
-----------------------	----------	----------

NOTA : Materiale Ghisa
NOTE : Material Cast iron

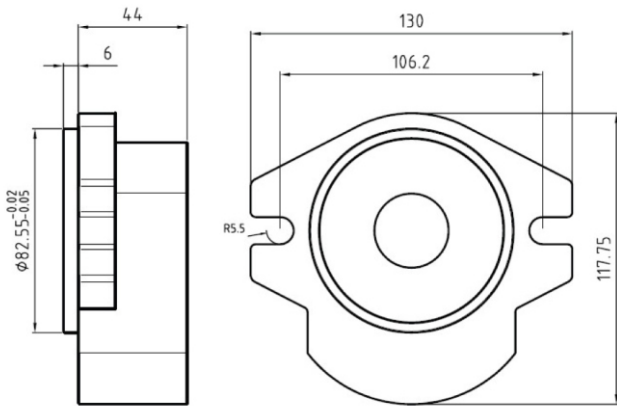

CODICE CODE	C	5
-----------------------	----------	----------

NOTA : Materiale Ghisa
NOTE : Material Cast iron

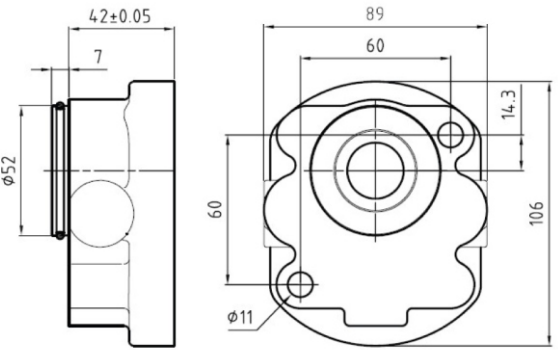

CODICE CODE	D	2
-----------------------	----------	----------

NOTA : Materiale Ghisa
NOTE : Material Cast iron

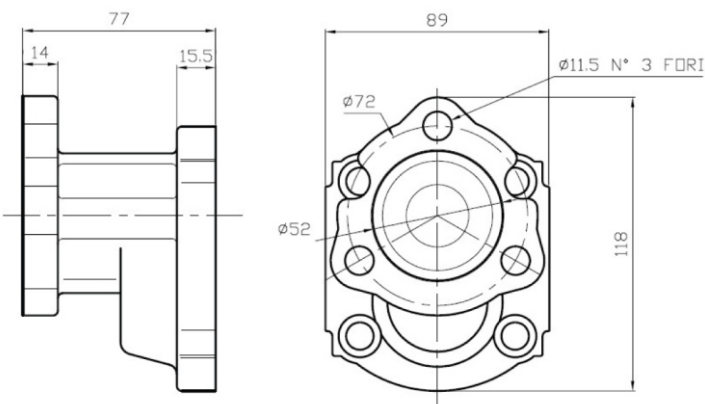

CODICE CODE	N	7
-----------------------	----------	----------

NOTA : Materiale Ghisa
NOTE : Material Cast iron

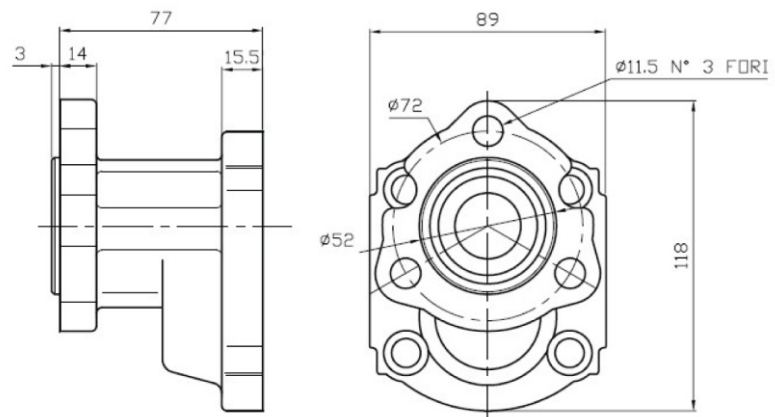

CODICE CODE	N	8
-----------------------	----------	----------

NOTA : Materiale Ghisa
NOTE : Material Cast iron

ALBERI
SHAFTS

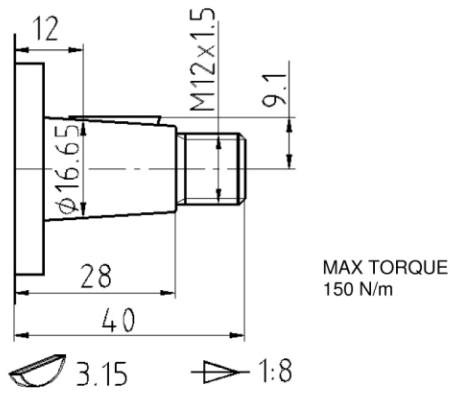

CODICE / CODE	C	
PER FLANGIA / FOR FLANGE	E	0

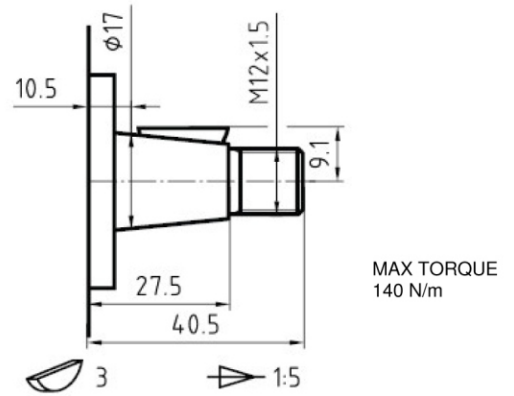

CODICE / CODE	A	
PER FLANGIA / FOR FLANGE	E	0

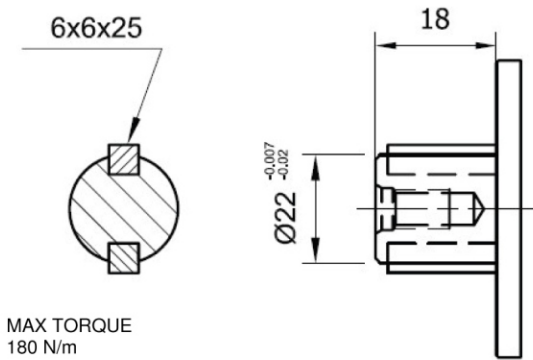

CODICE / CODE	N	
PER FLANGIA / FOR FLANGE	N	7

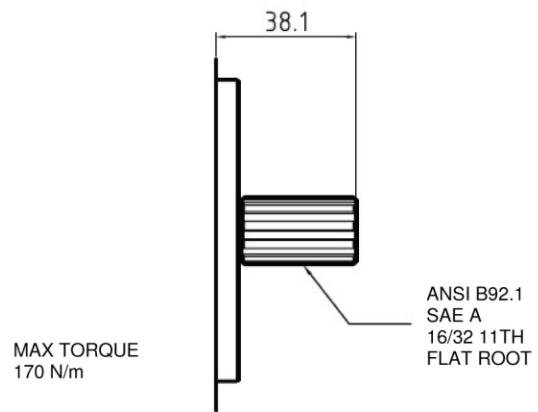

CODICE / CODE	I	
PER FLANGIA / FOR FLANGE	C	5

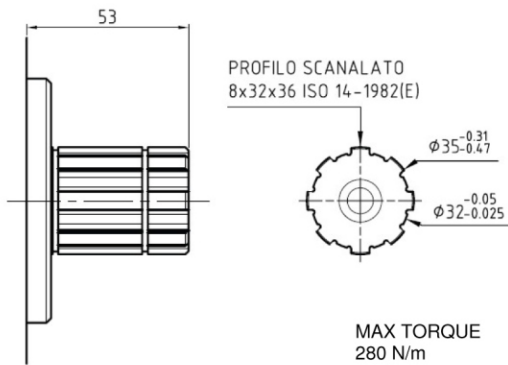

CODICE / CODE	H	
PER FLANGIA / FOR FLANGE	N	7
	I	4

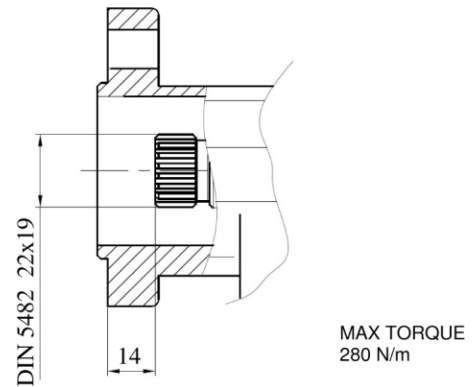

CODICE / CODE	F	
PER FLANGIA / FOR FLANGE	N	8

BOCCHIE DI ASPIRAZIONE E MANDATA LATERALI e POSTERIORI

SIDE AND REAR INLET AND OUTLET PORTS

ASPIRAZIONE <i>INLET</i>	M ANDATA <i>OUTLET</i>
------------------------------------	----------------------------------

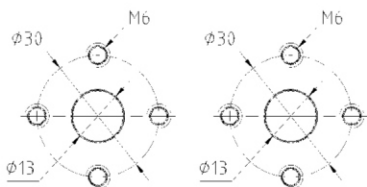

CODICE <i>CODE</i>	32
------------------------------	-----------

ASPIRAZIONE <i>INLET</i>	M ANDATA <i>OUTLET</i>
------------------------------------	----------------------------------

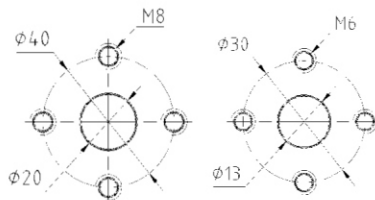

CODICE <i>CODE</i>	33
------------------------------	-----------

ASPIRAZIONE <i>INLET</i>	M ANDATA <i>OUTLET</i>
------------------------------------	----------------------------------

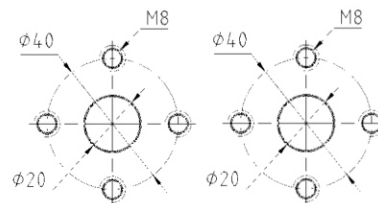

CODICE <i>CODE</i>	43
------------------------------	-----------

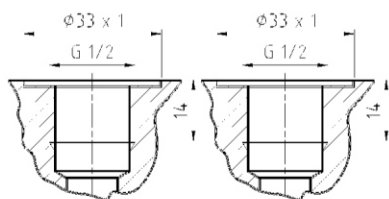

CODICE <i>CODE</i>	34
------------------------------	-----------

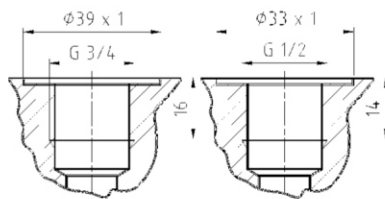

CODICE <i>CODE</i>	35
------------------------------	-----------

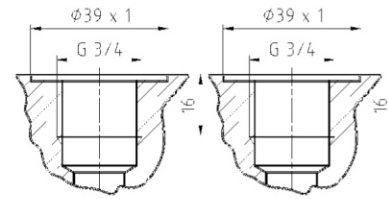

CODICE <i>CODE</i>	41
------------------------------	-----------

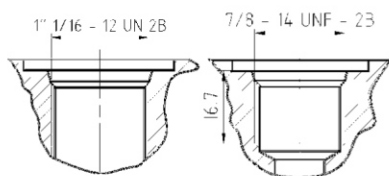

CODICE <i>CODE</i>	38
------------------------------	-----------

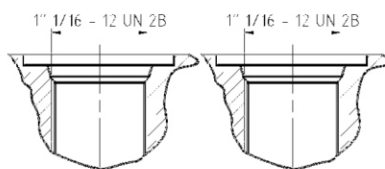

CODICE <i>CODE</i>	39
------------------------------	-----------

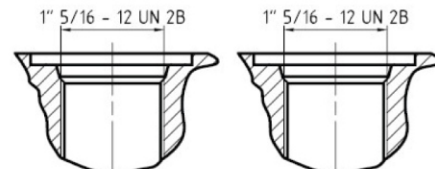

CODICE <i>CODE</i>	40
------------------------------	-----------

ISTRUZIONI PER L'ORDINAZIONE DI UNITA' SINGOLE W2
HOW TO ORDER W2 SINGLE UNITS

		1	2		3	4	5	6	7	9	10
0	2	W	E	G	06	C	0	32	D	N	X

1	TIPO UNITA' / UNIT TYPE	CODICE / CODE
	PUMP	W
	MOTOR	WM

2-5	FLANGIA / FLANGE (PAG. 7-8)	CODICE / CODE
	EUROPA / EUROPEAN	E - 0
	ISO / ISO	I - 4
	SAE A	C - 5
	TEDESCA / GERMAN	D - 2
	ITALIANA TIPO N / ITALIAN TYPE N	N - 7
	ITALIANA TIPO N / ITALIAN TYPE N	N - 8

3	CILINDRATA / CAPACITY cm ³	CODICE / CODE
	4.4	04
	6.3	06
	8.15	08
	11.3	11
	15.5	15
	20.5	20
	26.1	25
	38.8	40

4	ALBERO / SHAFT (PAG. 9-10)	CODICE / CODE
	CONICO 1:8 / TAPERED 1:8	C
	CILINDRICO Ø22 / STRAIGHT Ø22	N
	CONICO 1:5 / TAPERED 1:5	A
	ANSI B92.1SAE A 11TH 13/32 FLAT ROOT	I
	ISO 14-1982 8x32x36	H
	DIN 5482 22x19	F

6	BOCCHE / PORTS (PAG.11 -12)	CODICE / CODE
	EUROPEAN	32 - 34 - 43
	GAS	34 - 35 - 41
	ORING BOSS	38 - 39 - 40

7	ROTAZIONE / ROTATION	CODICE / CODE
	DESTRO / RIGHT	D
	SINISTRO / LEFT	S
	BIDIRECTIONAL WITH INTERNAL DRAIN	Y
	BIDIRECTIONAL WITH EXTERNAL DRAIN	R
	BIDIRECTIONAL WITH LATERAL DRAIN	R1

9	PARAOILIO / SHAFT SEAL (PAG.5)	CODICE / CODE
	STANDARD / STANDARD	N
	5 BAR NBR / 5 BAR NBR	R
	5 BAR VITON / 5 BAR VITON	RV
	DOPPIO MIM NBR / DOUBLE SEAL NBR	N2
	DOPPIO MIM VITON / DOUBLE SEAL VITON	V2
	25 BAR VARISEAL NBR / 25 BAR VARISEAL NBR	B
	25 BAR NBR / 25 BAR NBR	BN
	25 BAR VITON / 25 BAR VITON	BV

10	POSIZIONE BOCCHE / PORTS POSITION	CODICE / CODE
	LATERALE / LATERAL	X
	POSTERIORE / REAR	J

KIT DI MONTAGGIO POMPE MULTIPLE W2 CON STADI A FLUSSI SEPARATI
ASSEMBLING KITS FOR MULTIPLE PUMPS W2 WITH SEPARATED FLOW

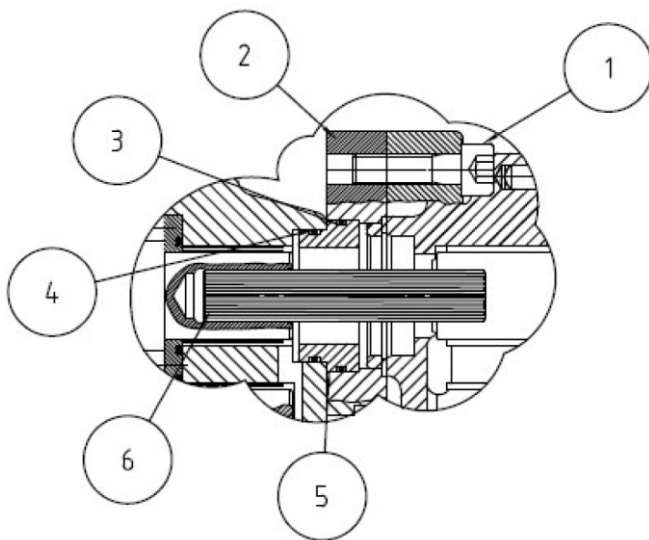
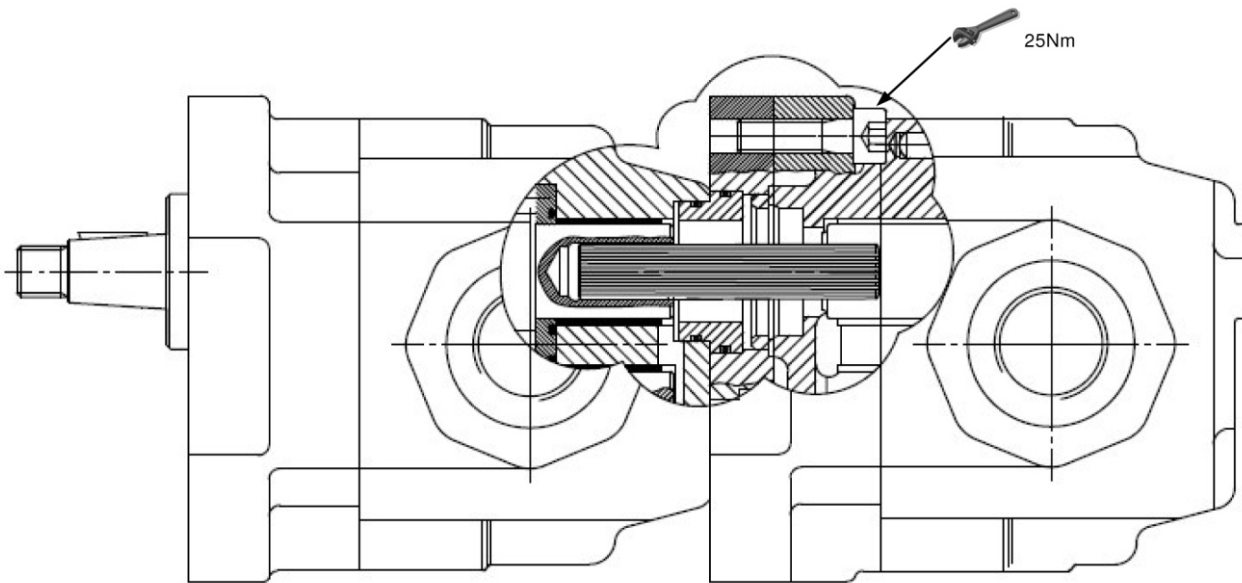

La pressione delle pompe intermedie e posteriori è limitata dalla tenuta dell'albero Z=25. La coppia max è **100 Nm**

*Max. shaft loading must conform to the limitations of shaft Z=25. Max torque is **100 Nm***

Ref	PARTI PARTS
1	M8 x 35 UNI 5931
2	Flangia intermedia <i>Intermediate flange</i>
3	OR2137
4	OR2118
5	Bussola di centraggio <i>Pilot ring</i>
6	Albero Z=25 <i>Splined shaft Z=25</i>

ISTRUZIONI PER L'ORDINAZIONE DI UNITA' M MULTIPLE W2
HOW TO ORDER W2 M MULTIPLE UNITS

			1		2		3		4		5		6		7
0	2	W	E	G	06	C	0	32	A	D	N				

POMPA ANTERIORE
FRONT PUMP

					2				5		6
0	2	W	E	G	06	0	0	32	I	D	

POMPA INTERMEDIA
MIDDLE PUMP

					2				5		6
0	2	W	E	G	06	0	0	32	P	D	

POMPA POSTERIORE
REAR PUMP

1 - 4	FLANGIA / FLANGE (PAG. 7-8)	CODICE / CODE
	EUROPA / EUROPEAN	E - 0
	ISO / ISO	I - 4
	SAE A	C - 5
	TEDESCA / GERMAN	D - 2
	ITALIANA TIPO N / ITALIAN TYPE N	N - 7
	ITALIANA TIPO N / ITALIAN TYPE N	N - 8

2	CILINDRATA / CAPACITY cm ³	CODICE / CODE
	4.4	04
	6.3	06
	8.15	08
	11.3	11
	15.5	15
	20.5	20
	26.1	25
	38.8	40

3	ALBERO / SHAFT (PAG. 9-10)	CODICE / CODE
	CONICO 1:8 / TAPERED 1:8	C
	CILINDRICO Ø22 / STRAIGHT Ø22	N
	CONICO 1:5 / TAPERED 1:5	A
	ANSI B92.1 SAE A 11 TH 13/32 FLAT ROOT	I
	ISO 14-1982 8x32x36	H
	DIN 5482 22x19	F

5	BOCCHIE / PORTS (PAG.11 -12)	CODICE / CODE
	EUROPEAN	32 - 33 - 43
	GAS	34 - 35 - 36
	SAE	38 - 39 - 40

7	ROTAZIONE / ROTATION	CODICE / CODE
	DESTRO / RIGHT	D
	SINISTRO / LEFT	S
	BIDIRECTIONAL WITH INTERNAL DRAIN	Y
	BIDIRECTIONAL WITH EXTERNAL DRAIN	R

7	PARAOLIO / SHAFT SEAL (PAG.5)	CODICE / CODE
	STANDARD / STANDARD	N
	5 BAR NBR / 5 BAR NBR	R
	5 BAR VITON / 5 BAR VITON	RV
	DOPPIO MIM NBR / DOUBLE SEAL NBR	N2
	DOPPIO MIM VITON / DOUBLE SEAL VITON	V2
	25 BAR VARISEAL NBR / 25 BAR VARISEAL NBR	B
	25 BAR NBR / 25 BAR NBR	BN
	25 BAR VITON / 25 BAR VITON	BV

SUPPORTO PER APPLICAZIONE SU M ACCHINE AGRICOLE
OUTBOARD BEARINGS FOR AGRICULTURAL MACHINE

SEM 2

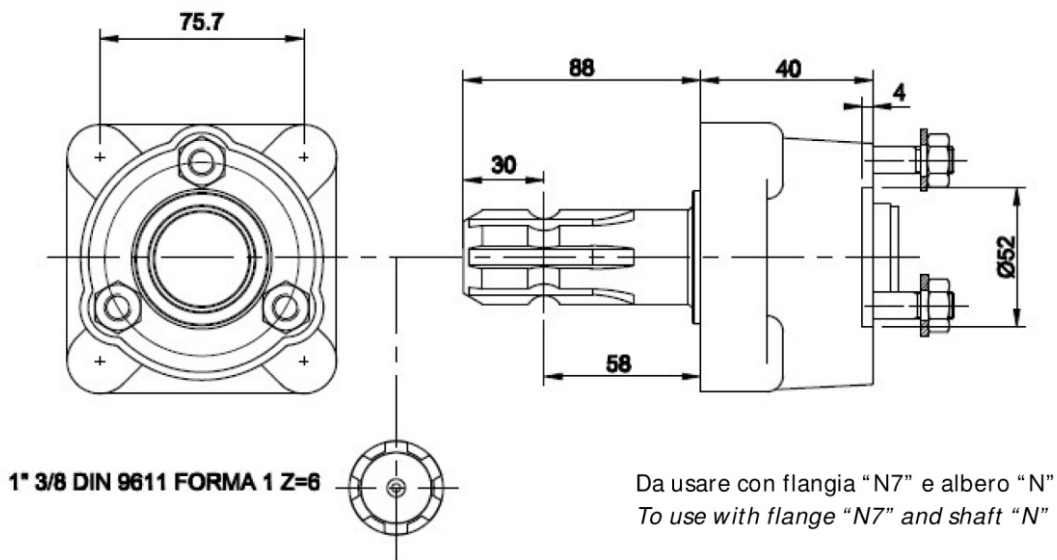

Carico radiale 780 N - carico assiale 800N
 Radial load 780 N - axial load 800 N

SER 2

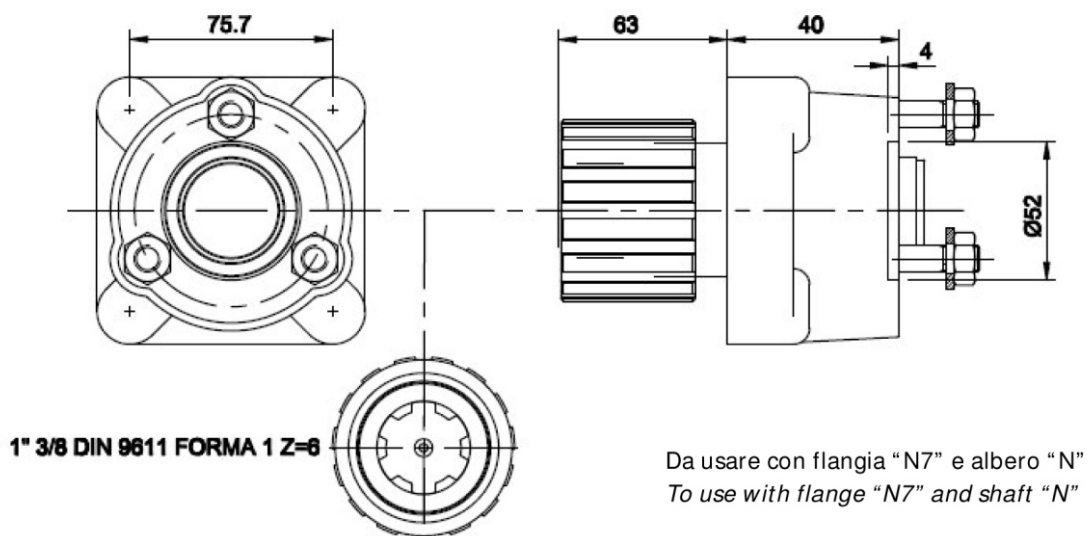

Carico radiale 780 N - carico assiale 800N
 Radial load 780 N - axial load 800 N





